



Battlezone™ Riflescope Owner's Manual

Complete Installation & Operating Instructions

The Redfield® Story

Born in 1859 on a farm near Glendale, Oregon, John Hill Redfield was one of eight children of John and Adelia Redfield.

As a boy, John loved to hunt and explore the regions around the homestead. Eventually, John's mechanical aptitudes and inventiveness led him into the firearms industry, and in 1909, John started the Redfield Gun Sight Co.

A small building behind his home served as his first factory. From this humble beginning, the company expanded its offerings to include scope mounts and eventually a premier line of riflescopes for which it was widely known.

In 1997, Redfield closed its manufacturing facility in the United States and spent most of the next decade languishing as a name used by various companies.

In 2008, Leupold & Stevens, an Oregon company with a long tradition of manufacturing optical instruments, purchased the Redfield optics brand and committed to bringing hunters a new generation of Redfield riflescopes. These new products embody the values that Leupold and Redfield shared: ruggedness, performance, durability, and value. We hope your new Redfield riflescope brings you years of success and enjoyment in the field.

Before You Start

PLEASE READ THIS ENTIRE HANDBOOK BEFORE MOUNTING YOUR SCOPE.

CAUTION:



Always check and be certain that the firearm is unloaded before undertaking any work upon it.

Know Your Scope

Riflescopes have become far more sophisticated over the years, but the four most basic parts have remained the same. Working from front to back they are:

1. The objective lens (*front lens*) is critical to a superior sight picture.
2. The internal erector lenses which right the image.
3. The reticle, often referred to as the crosshair, provides the aiming point.
4. The ocular lens (*or eyepiece lens*) works with the other lenses to magnify the image and make diopter corrections.

HOW SCOPES WORK

As light passes through and beyond the objective lens, the resulting upside down image is sent to the internal lenses. Known as erector lenses, these internal lenses return the image to a right-side-up position. Finally, the ocular lens makes a final enlargement of that image and sends it on to your eye.

Your Redfield scope was designed, manufactured, and tested to ensure that, when properly mounted and sighted-in on your firearm, you will enjoy exceptional performance. A solid mount is critical to satisfactory performance of your scope. If you have problems or questions, please contact Redfield Product Service.

PARTS OF THE SCOPE

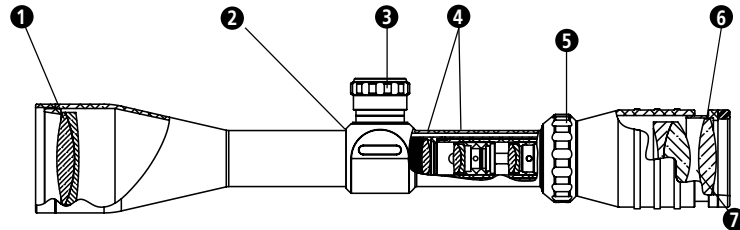

- | | |
|---|------------------------|
| 1. Objective Lens | 4. Erector Lenses |
| 2. Windage Adjustment
(opposite side of scope) | 5. Power Selector Ring |
| 3. Elevation Adjustment | 6. Ocular Lens |
| | 7. Eyepiece Assembly |

How to Install the Scope

THE LOWER THE SCOPE, THE BETTER

A scope mounted close to the rifle ensures proper cheek weld on the stock for a stable firing position and allows for rapid target acquisition. We recommend using the lowest possible ring height. No specific clearance is required, but the scope must clear the bolt handle, hammer (on lever actions), sights, and barrel.

When installed, be sure that your scope does not interfere with firearm operation and does not contact anything except the mount rings.

INSTALLING THE BASE, RINGS, & SCOPE

Please refer to the instructions included with the base and rings for their proper installation on the firearm.

NOTE: The windage and elevation adjustments on new Redfield scopes are centered as part of the assembly process. If you are mounting a scope that was previously mounted on another rifle, you should center the adjustments (please see "Centering Windage and Elevation Adjustments" section for more details).

ESTABLISHING EYE RELIEF ON RIFLES & SHOTGUNS

Because of the safety considerations associated with proper eye relief, Redfield strongly recommends that you mount your scope as far forward as possible. Beyond that, follow these steps:

1. With the scope as far forward in the mounts as possible, hold the rifle in your normal shooting position. Scopes should be set at the highest magnification for this process.
2. Slowly move the scope to the rear just until you can see a full field-of-view.
3. Position your scope here for maximum eye relief.
4. Proceed to COMPLETING THE INSTALLATION.

NOTE: To confirm that your scope is mounted in the best possible position, try assuming various positions: kneeling, seated, prone, and aiming both uphill and downhill. Remember that aiming uphill typically reduces eye relief. Wearing hunting/shooting specific clothing is recommended as this may alter eye relief considerations slightly.

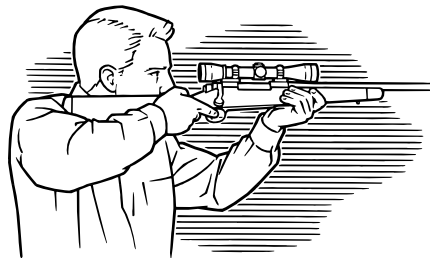

Redfield riflescopes are engineered to provide a generous 3" to 5" eye relief, depending on the model and the magnification level.

WARNING:



If a scope is mounted too far to the rear, the eyepiece can injure the shooter's brow. Shooting at an uphill angle also increases this hazard because it shortens the distance between the brow and the rear of the scope. For this reason, Redfield scopes are engineered to provide generous eye relief. Therefore, when mounting your scope, we recommend positioning it as far forward in the mounts as possible to take full advantage of this generous eye relief.

COMPLETING THE INSTALLATION

Without disturbing the optimal eye relief position, rotate the scope until the elevation adjustment dial is at the top of the scope.

From a firing position, check to be sure that the vertical line of the reticle aligns with the vertical axis of the firearm. Misalignment will not affect accuracy at moderate distances but it can diminish long range accuracy.

When you are satisfied, tighten the ring screws evenly and securely following the instructions included with the rings.

FOCUSING THE RETICLE

Secure the scope and firearm in a firm rest. Safely point the scope at a light colored background object. With the scope approximately four inches from your eye the reticle should appear sharp and crisp; if it does not, it is necessary to adjust the focus by means of the rubber ring on the eyepiece following these steps:

1. If you tend to hold things away from yourself to see them clearly (you are farsighted) turn the rubber ring counter-clockwise. If you hold things close to yourself to see them clearly (you are nearsighted) turn the ring clockwise.

2. Looking through the scope when pointed at a light colored background object, take a few quick glances at the reticle. The focus of the reticle should be noticeably different from when you started. Continue this process until the reticle appears clear and sharp.
3. If your eyesight changes, readjust the eyepiece. As we age, eyesight normally changes. You may want to check the sharpness of the reticle on your scope every few years to ensure it is still adjusted correctly for your eye.

NOTE: To protect the integrity of the waterproof seal of every Redfield scope, an internal mechanism prevents the eyepiece from being removed.

The primary function of a scope is to aim the firearm. Never use the scope as a substitute for binoculars. Never watch another person through the scope. As always, safety first.

WHAT YOU SHOULD KNOW ABOUT VARIABLE POWER SCOPES

Redfield variable power scopes allow you to select from a range of magnifications to suit your particular rifle, cartridge, and shooting needs.

WARNING: *Do not loosen the screw in the power selector ring. Doing so will release the internal gas that keeps the scope fog free. Loosening the screw will also disconnect a pin that controls the internal operations, causing other problems that will require factory repairs. Do not lubricate the power selector ring; doing so is unnecessary.*

All variable power scopes have a power selector ring in front of the eyepiece assembly. Turn the ring to align the indicator marked on the ring with the desired magnification marked on the body of the scope.

UNDERSTANDING PARALLAX

Parallax is the apparent movement of the target relative to the reticle when you move your eye away from the center point of the eyepiece. It occurs when the image of the target does not fall on the same optical plane as the reticle. This can cause a small shift in the point of aim.

Maximum parallax occurs when your eye is at the very edge of the exit pupil. (Even in this unlikely event, our 4x hunting scope focused for 150 yards has a maximum error of only 8/10ths of an inch at 500 yards.)

At short distances, the parallax effect does not affect accuracy. (Using the same 4x scope at 100 yards, the maximum error is less than 2/10ths of an inch.) It is also good to remember that, as long as you are sighting

straight through the middle of the scope, or close to it, parallax will have virtually no effect on accuracy in a hunting situation.

ABOUT FIXED PARALLAX DISTANCE SCOPES

Any fixed focus optical system can be adjusted to be parallax free at only one distance. Most Redfield scopes are adjusted at the factory to be parallax free at 150 yards. However, there are exceptions:

1. The Battlezone 3-9x42mm scopes are parallax free at 100 yards. Battlezone Tac.22 scopes are set to be parallax free at 75 yards.

ADJUSTABLE OBJECTIVE INSTRUCTIONS

Select models feature an Adjustable Objective to eliminate parallax. Parallax is the apparent movement of the reticle relative to the target when you move your eye away from the center of the eyepiece. The Focus Ring moves a lens within the optical system to ensure the target image and reticle fall on the same focal plane to provide optimal accuracy. It is important to note that as long as you are sighting directly through the middle of the scope, or close to it, parallax will have virtually no effect on accuracy in a hunting situation.

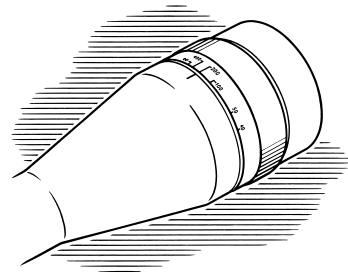

*To adjust the parallax distance,
turn the focus ring.*

To eliminate parallax in adjustable objective scopes follow these steps

1. The reticle should be clear (focused) before adjusting the parallax. If it is not, follow the instructions under "Focusing the Reticle." See pages 8 & 9.
2. With the firearm in a stable position, look through the scope, concentrating on the center aiming point of the reticle.
3. Move your head slightly up and down while turning the adjustable objective ring until the reticle does not move in relation to the target.

Note: By estimating the range to the target and using the numbers on the adjustable objective ring, you can get your parallax adjustments close to the proper setting before assuming a shooting position.

Note: Settings may vary slightly per individual preferences, eyesight, air temperature, and atmospheric conditions.

How to Sight-In

USING A BORE-SIGHTING COLLIMATOR

To save time and ammunition, start out in your shop or gun room with a bore-sighting collimator. Follow the directions included with the collimator for specific instructions on its proper use. Remember, when possible, it is better to make the initial windage adjustments to the mount base before using the scope's windage adjustment. Leupold STD mounts provide the maximum adjustment travel by providing windage adjustment in the mount system. When using STD mounts, always make the windage adjustment in the mount first, then refine this setting using the riflescope windage adjustment.

NOTE: Bore-sighting alone is not sufficient to sight-in a scope. You must make final adjustments by shooting the firearm using the same ammunition you use in the field.

USING THE LEUPOLD® ZERO POINT® ILLUMINATED MAGNETIC BORESIGHTER

This tool fits any rifle, shotgun, or pistol, and helps you get "on the paper" fast, without barrel spuds. It works with any optical sight, and can even be used to recheck your zero, without firing a shot. See your Leupold Dealer or visit www.leupold.com for more information.

TRADITIONAL BORE-SIGHTING

Preliminary sighting-in can also be accomplished by bore-sighting at the firing range using a target from 20 to 50 yards away.

1. Remove the bolt from the firearm. If using a Modern Sporting Rifle (MSR) or AR-15 variant, separate the upper and lower receiver halves.
2. Position the firearm on the bench, using sandbags to steady the firearm.
3. Looking through the bore itself, move the firearm to center the bull's-eye of the target inside the barrel, as shown in Figure A.
4. Hold the rifle steady. With the bull's-eye centered when viewed through the bore, make windage and elevation adjustments to the scope until the very center of the reticle is aligned with the bull's-eye of the target, as shown in Figure B.

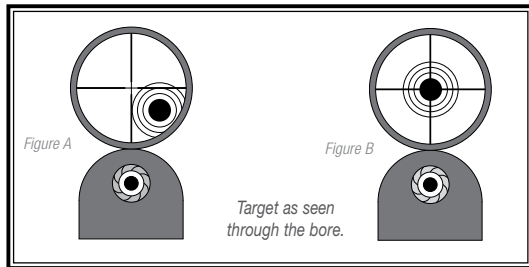

THE FINAL STEP: THREE-SHOT GROUPS

Whichever bore-sighting method you've used, the next steps are the same on the firing range. To ensure reliable results, always fire from a rested position when performing these steps.

1. Fire a shot or two.
2. If you are several inches off center, make an appropriate amount of adjustment to move the reticle to the center of the target.
3. Carefully fire a three-shot group.
4. Use the center of that group as a reference point for the final adjustments to windage and elevation.

On the sample target, the center of the group is two inches low and three inches right. Assuming you're sighting-in at 100 yards, you should make a 2-MOA adjustment up, and a 3-MOA adjustment left. Your next three-shot group should be very close to the center of the target. To learn about making final adjustments, proceed to the upcoming section on windage and elevation adjustments.

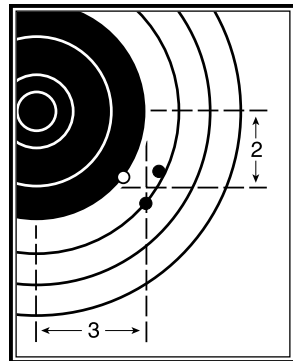

Making Precise Windage & Elevation Adjustments

Battlezone scopes feature 1/4 MOA precision finger-click / resettable adjustments, and the letters found on the elevation and windage dials refer to the direction that the point-of-impact of the bullet is moved when an adjustment is made. To make an elevation correction, simply rotate the dial the necessary amount. The adjustment will move the bullet impact in the direction indicated on the dial. For example, if you would like the bullet to impact 2 inches higher at 100 yards, you would rotate the elevation dial 8 clicks (2 MOA) in the "up" (counter-clockwise) direction.

The same is true for windage adjustments. To make a windage correction simply rotate the dial in the left or right direction the appropriate number of clicks.

BULLET DROP COMPENSATION DIALS

Special bullet drop compensation (BDC) elevation dials are featured on Battlezone scopes. These dials are calibrated to achieve adjustment to specific distances rapidly by distance indicators marked directly on the dials. The dials are marked in 50 yard increments that are keyed to particular ballistic profiles of popular .223 (5.56x45mm) and .308 (7.62x51mm) rounds, however the dials will work with many cartridges that have similar ballistic profiles. The Battlezone Tac.22 BDC dials are calibrated for a .22 Long Rifle and the yardage increments vary slightly compared to those mentioned earlier. We recommend that you zero your scope at the shortest distance for which you have a reference mark on the dial; 100 yards. During sight-

in, ignore the distance indicators on the elevation adjustment and follow the standard zeroing procedure.

SWAPPING/REPLACING BULLET DROP COMPENSATION DIALS

Select Redfield Battlezone riflescopes are shipped with an additional bullet drop compensation dial. To swap or replace the BDC dial follow these simple steps:

Caution: Adjustment dial set screws are under spring tension. Take care to retain the set screw and spring!

1. Hold the elevation dial from spinning while using the supplied hex wrench to completely loosen the set screw in the center of the elevation dial assembly. The screw is under spring tension, so ensure that the set screw AND spring are captured when the screw is loosened.

2. Lift the BDC dial up and away from the elevation adjustment assembly.
3. Install the alternate dial over the elevation adjustment assembly.
4. Reinstall the set screw and spring, ensuring that the spring is around the smooth portion of the shaft.
5. Hold the dial from spinning while using the supplied hex wrench to tighten the set screw.

Caution: Do not over-tighten the set screw.

Occasionally the set screws and/or included wrench become worn or lost and require replacement. If you require a replacement screw, spring, or wrench we will be happy to send replacements. Refer to "Redfield Product Service" section for ordering.

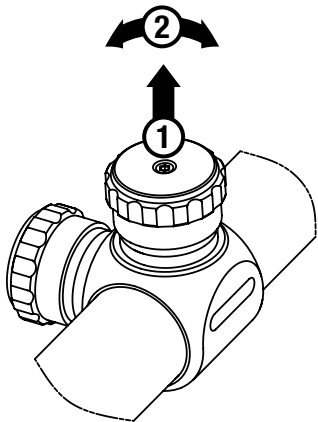

Pull up (1), then turn to set dial to "0" by turning dial left or right (2). Release once "0" is lined up with the witness line.

ZEROING THE WINDAGE & ELEVATION DIALS AFTER SIGHTING IN

Redfield scopes feature adjustment dials that can be repositioned to align with the marked zero indicator of the adjustment without changing the adjustment setting of the scope. This allows the shooter to know the original zero of the rifle in the event that further adjustments are made in the field.

To reset the windage simply lift the dial and rotate it until the "0" on the dial is aligned with the zero indicator of the adjustment. To reset the elevation simply lift the dial and rotate it until the distance that the rifle was sighted in at is aligned with the zero indicator of the adjustment.

CENTERING WINDAGE & ELEVATION ADJUSTMENTS TO ACHIEVE OPTIMUM ADJUSTMENT TRAVEL

Making windage and elevation adjustments moves the entire erector system horizontally and vertically inside the scope. Redfield

Battlezone riflescopes are shipped from the factory with the adjustments centered optically in the system, however if the erector system is off to one side – as a result of having been mounted on a non-adjustable mount – the adjustments won't provide equal travel in all directions. To regain full balanced travel, you must recenter the adjustment as follows:

1. Turn the windage adjustment to the point that it stops moving.
2. Counting the clicks or hash marks, turn it all the way in the other direction.
3. Turn the dial back half the amount of clicks or hash marks counted.
4. Repeat this process for the elevation adjustment.

TAG-MOA RETICLE

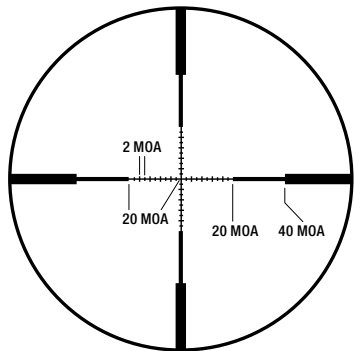

2-7x and 3-9x

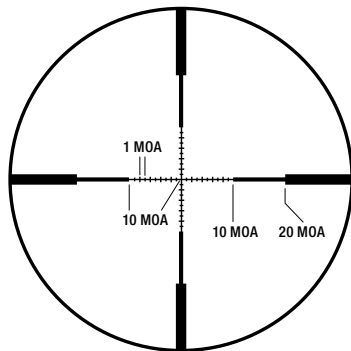

6-18x

Redfield Means Minimal Maintenance

LENSES

Redfield scope lenses are coated to reduce light reflections and light scattering, thus increasing light transmission through the scope. They should be cleaned as carefully as a camera lens. Begin by using a lens brush to remove dust and then pure alcohol, high-grade glass cleaner, or pure water on a cotton swab.

WINDAGE / ELEVATION ADJUSTMENTS

These adjustments are permanently lubricated. There is no need to lubricate them. Keep the adjustment covers on, except when adjusting, to

keep out dust and dirt.

EYEPIECE ADJUSTMENT

This adjustment is permanently lubricated. There is no need to lubricate it. The eyepiece can be rotated as far as it will go in either direction. An internal lock ring prevents inadvertent removal of the eyepiece.

SEALS

Redfield scopes are sealed from within by several methods, including O-rings. All seals are permanent and require no maintenance.

SCOPE EXTERIOR

Redfield scopes are made of a rugged aircraft aluminum alloy. No maintenance of any kind is required; simply wipe off any dirt or fingerprints that accumulate with a clean, dry cloth.

POWER SELECTOR RING

No lubrication is ever required on the power selector ring. **DO NOT LOOSEN OR REMOVE THE HEX-HEAD SCREW IN THE POWER SELECTOR RING.**

TROUBLE SHOOTING TIPS

Before you ship a scope back to the factory for service or repair, please check the following items.

1. Check the mount. Make sure the scope is mounted securely to the rifle. Try, with bare hands only, to gently twist the scope in the rings or see if anything moves when you jiggle it. If there is any movement, retighten the mounting system according to mounting instructions.
2. Make sure the action of your rifle is properly bedded in the stock, and that all receiver screws are tight and have been tightened in the sequence recommended by the manufacturer. A loosely fitted stock can cause changes to the point-of-impact.
3. When test firing a rifle to check the point-of-impact relative to windage and elevation adjustments, be sure to fire from a solid bench with sandbags supporting the forearm and buttstock.

4. Be sure to use factory-loaded ammunition of the same bullet type, weight, and preferably, lot number. If one type of ammunition does not shoot well, try another brand or bullet weight.
5. Be certain that both the barrel and chamber are clean. Heavy factory grease or copper fouling can diminish the accuracy of the firearm.

Redfield Product Service

If your Redfield scope fails to perform in any way, you may return it directly to the factory (or one of our international service centers) for service. It is not necessary for your dealer to ship the scope to Redfield; however, they can be very helpful in determining if factory service is necessary. Please follow these shipping instructions:

1. Remove the rings and any other accessories from the scope.
2. Record the serial number of the scope and keep it for your records.
3. Include a note with your name, address, telephone number, E-mail, and a description of the problem.
4. Pack the scope in its original box if possible, as this is the safest shipping container. Wrap the package

securely using filament strapping tape on the outside.

5. Ship the scope by parcel or mail service (insured, if possible) to one of the following addresses:

In the United States:

Parcel Service:

Redfield Product Service
14400 NW Greenbrier Parkway
Beaverton, OR 97006-5790 USA

By Mail:

Redfield Product Service
P.O. Box 688
Beaverton, OR 97075-0688 USA

Outside the United States:

Canada: Korth Group Ltd.,
103 Stockton Point, Box 490
Okotoks, AB T0L 1T0, Canada

Germany: Harold Ros,
Coburger Strasse 71,
98673 Eisfeld, Germany

Sweden: HDF Gyttop Jakt AB, Svarvaregatan 5,
S-302 50 Halmstad, Sweden

Our Product Service telephone numbers are (503)
526-1400 or (800) LEUPOLD (538-7653), fax is (503)
352-7621.

They can also be contacted through our Web site at
www.redfield.com.

Consumer Protection You Can Trust

REDFIELD: "NO EXCUSES"

We build our Redfield riflescopes, sights, binoculars, spotting scopes and laser rangefinders to do their jobs. Day after day. Season after season. It's what you expect for your hard earned money.

If you ever have an issue, the last thing you need is backpedaling and passing the buck. That's where our No Excuses Warranties come in. If you have a problem with your Redfield product, we will make it right. No Hassle, No Excuses. That's the Redfield way. Please see www.redfield.com for warranty details.

THE REDFIELD "NO EXCUSES" FULL LIFETIME WARRANTY

Redfield non-electronics products are warranted for as long as the owner owns them. We warrant them to be free of defects in materials and workmanship and function at a high level under normal use conditions. If at any time a Redfield non-electronic product is found to have a defect in materials or workmanship, Redfield will, at our discretion, repair or replace it free of charge, when requested by the original owner.

All warranties are void if damage results from unauthorized repair, alteration or misuse.

The Redfield Lifetime Warranty in Germany and other countries where legally prohibited: Redfield is convinced of the high-quality and reliability of its riflescopes. This is why each U.S. customer is afforded a lifetime warranty. For legal reasons, this warranty must be restricted to 30 years in Germany and other countries where a lifetime warranty is prohibited. Each owner, even those that acquired a Redfield product that was previously owned and used, can make use of this 30 year guarantee.

REDFIELD MAKES MORE THAN SCOPES

See our complete line of rangefinders, binoculars, and spotting scopes at your nearest Redfield dealer.

For a free Redfield catalog, write to: Redfield, Inc., P.O. Box 688, Beaverton, OR 97075, call (503) 526-1400 or (800) LEUPOLD (538-7653), or send us an E-mail through our Web site at www.redfield.com.

The Redfield package is made in part from recycled materials and is 100% recyclable. Many Redfield owners keep their scope boxes. If you have no use for yours, we encourage you to dispose of it responsibly.



A brand of Leupold & Stevens Inc.

Leupold & Stevens, Inc. reserves all other rights. Redfield, Tracker, Accu-Range, Accu-Ranger, Accu-Trac, 4-Plex, Revolution and Revenge are registered trademarks of Leupold & Stevens, Inc., Beaverton, Oregon. Bear Cub, Battlezone, and Orion are trademarks of Leupold & Stevens, Inc. Beaverton, Oregon.

Note: We reserve the right to make design and/or material modifications without prior notice.

This publication may not be reprinted or otherwise reproduced without the expressed written consent of Leupold & Stevens, Inc.

Copyright © 2013 Leupold & Stevens, Inc. All rights reserved.

Part # 117925 Artwork # 117926C